

National Pollutant Discharge Elimination System/State Disposal System

MN0064190

Permittee: City Of Otsego
Facility name: Otsego East Wastewater Treatment Facility
Receiving water: Crow River - Class 2Bg, 3, 4A, 4B, 5, 6 water
City: Otsego **County:** Wright
Issuance date: To be determined (TBD)
Expiration date: TBD

The state of Minnesota, on behalf of its citizens through the Minnesota Pollution Control Agency (MPCA), authorizes the Permittee to operate a disposal system at the facility named above and to discharge from this facility to the receiving water named above, in accordance with the requirements of this permit.

The goal of this permit is to reduce pollutant levels in point source discharges and protect water quality in accordance with the U.S. Clean Water Act, Minnesota statutes and rules, and federal laws and regulations.

This permit is effective on the issuance date identified above. This permit expires at midnight on the expiration date identified above.

Signature: *[Type e-Signature]*

This document has been electronically signed.

for the Minnesota Pollution Control Agency

Benjamin Carlson-Stehlin (P.E.)
Supervisor
Metro Regional and Infrastructure Financing
Municipal Division

Resources

Submit electronic Discharge Monitoring Reports (eDMR) via the MPCA e-Services at:
https://rsp.pca.state.mn.us/TEMPO_RSP/Orchestrate.do?initiate=true

Submit documents electronically to wq.submittals.mpca@state.mn.us. **Note:** The Water quality submittals form located at <https://www.pca.state.mn.us/sites/default/files/wq-wwprm7-71.docx> must be attached.

For eDMR and other permit reporting issues, use the directory listed at the bottom of the Discharge Monitoring Report page: <https://www.pca.state.mn.us/water/discharge-monitoring-reports>

For specific permit requirements, contact your compliance staff: <https://www.pca.state.mn.us/water/wastewater-compliance-and-enforcement-staff-contacts>

For wastewater permit program general questions, contact the MPCA at 651-282-6143 or 800-657-3938, or reference the permit user's manual at <https://www.pca.state.mn.us/sites/default/files/wq-wwtp7-09.pdf>.

Additional guidance and resources are located at: <https://www.pca.state.mn.us/water/wastewater>.

A printable summary of sampling requirements can be found at: <https://www.pca.state.mn.us/water/wastewater-permit-submittal-checklists>.

A printable checklist of submittals can be found at: <https://www.pca.state.mn.us/water/wastewater-permit-submittal-checklists>

Table of Contents

	Page
1. Permitted facility description.....	4
2. Location map of permitted facility.....	5
3. Flow diagram.....	6
4. Summary of stations and station locations.....	7
5. Permit requirements.....	8
6. Submittal action summary	32
7. Limits and monitoring.....	33

DRAFT

1. Permitted facility description

The Otsego East Wastewater Treatment Facility (facility) is located at 5850 Randolph Ave NE, Otsego, Minnesota 55374-4904, Wright County.

Existing Facility

The existing facility has a continuous discharge from SD 001. The facility is a Class A.

The facility is designed to treat:

- an average wet weather (AWW) flow of 1.1 million gallons per day (MGD);
- an average dry weather (ADW) flow of 0.9 MGD;
- a peak hourly wet weather (PHWW) flow of 3.294 MGD;
- a peak instantaneous wet weather (PIWW) flow of 4.032 MGD; and
- five-day biochemical oxygen demand (BOD₅) of 2,082 pounds per day (lb/d).

The facility consists a bar screen, a parshall flume, a mechanical fine screen, a grit chamber, a flow splitter, three anaerobic/anoxic selector basins, three oxidation ditches, a flow splitter, chemical addition for phosphorus removal, two final clarifiers, ultraviolet disinfection, and effluent aeration.

Biosolids treatment consists of three aerobic sludge storage tanks, sludge storage tanks, gravity belt thickening, centrifuge dewatering, a centrate storage tank, and Schwing Bioset reactor technology. Thickened waste activated sludge is received from the Otsego West WWTP for treatment. Biosolids are land applied and landfilled.

Proposed Facility

The proposed facility will have a continuous discharge from SD 001. The facility is a Class A.

The facility will be designed to treat:

- an AWW flow of 1.65 MGD;
- an ADW flow of 1.35 MGD; and
- BOD₅ of 3,124 lb/d.

The facility modifications will consist of an expansion of screening and UV disinfection capacity, equipping an additional existing oxidation ditch structure, and plumbing/HVAC/electrical/SCADA improvements.

Changes to the facility may result in an increase in pollutant loading to surface waters or other causes of degradation to surface waters. If a change to the facility will result in a net increase in pollutant loading or other causes of degradation that exceed the maximum loading authorized through conditions specified in the existing permit, the changes to the facility are subject to antidegradation requirements found in Minn. R. 7050.0250 to 7050.0335.

This Permit also complies with Minn. R. 7053.0275 regarding anti-backsliding.

Any point source discharger of sewage, industrial, or other wastes for which a National Pollutant Discharge Elimination System (NPDES) permit has been issued by the MPCA that contains effluent limits more stringent than those that would be established by Minn. R. 7053.0215 to 7053.0265 shall continue to meet the effluent limits established by the permit, unless the permittee establishes that less stringent effluent limits are allowable pursuant to federal law, under section 402(o) of the Clean Water Act, United States Code, title 33, section 1342.

2. Location map of permitted facility

Facility Location Map
Otsego East WWTP: MN0064190
T120N, R26W, Section 01
Otsego, Wright County, Minnesota



Map produced by: MPCA Staff, 10/20/2025
Scale: 1:12,000

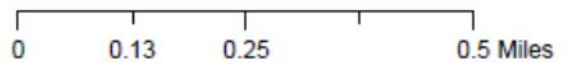

3. Flow diagram

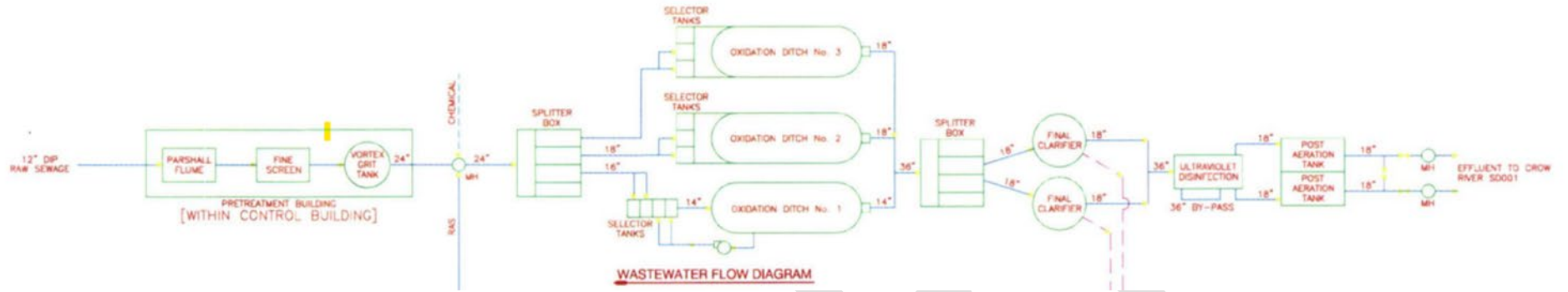

DRAFT

4. Summary of stations and station locations

Station	Type of station	Local name	PLS location
SD 001	Effluent To Surface Water	Surface Water Discharge	T120N, R23W, S01, SE Quarter of the NW Quarter
WS 001	Influent Waste	Influent Waste Stream	T120N, R23W, S01, NE Quarter of the NW Quarter

DRAFT

5. Permit requirements

SD 001	Effluent To Surface Water	
Surface Discharge: Class A Major Facility Effluent Requirements		
	5.1.1	The Permittee shall submit a monthly DMR : Due by 21 days after the end of each calendar month following permit issuance. [Minn. R. 7001.0150, subp. 2(B)]
	5.1.2	Sampling Location. [Minn. R. 7001.0150, subp. 2(B)]
	5.1.3	Samples for Station SD 001 shall be taken at a point representative of the total facility discharge. [Minn. R. 7001.0150, subp. 2(B)]
Priority Pollutant Requirements		
	5.2.4	Monitoring Frequency. [Minn. R. 7001]
	5.2.5	The Permittee shall monitor the effluent three times in the life of the permit for the following specified priority pollutants. Sampling events shall occur before the second, third, and fourth year following permit issuance and shall not be less than one year apart. [Minn. R. 7001]
	5.2.6	The Permittee shall submit the first priority pollutant monitoring report : Due 1095 calendar days before Permit Expiration Date. (By two years after permit issuance date). [Minn. R. 7001]
	5.2.7	The Permittee shall submit the second priority pollutant monitoring report : Due 730 calendar days before Permit Expiration Date. (By three years after permit issuance date). [Minn. R. 7001]
	5.2.8	The Permittee shall submit the third priority pollutant monitoring report : Due 365 calendar days before Permit Expiration Date. (By four years after permit issuance date). [Minn. R. 7001]
	5.2.9	Sample Type. [Minn. R. 7001]
	5.2.10	All samples should be collected using a 24-hour flow proportional composite; except for the 624 volatiles, cyanide, and 1631E mercury samples, which must be collected using the grab method. [Minn. R. 7050.0222]
	5.2.11	Reporting Specifics. [Minn. R. 7001]
	5.2.12	Reporting limits for all Priority Pollutant analyses shall be as close as analytically possible to the Class 2B chronic water quality standards. [Minn. R. 7050.0222]
	5.2.13	Monitoring Specifics. [Minn. R. 7001]
	5.2.14	<p>Monitoring shall be for the organic priority pollutants identified under the volatile, acid, base/neutral, and pesticide fractions using EPA methods 624, 625, and 608 (40 CFR pt. 136) as listed in Table II of 40 CFR pt. 122, Appendix D or any updates to those methods.</p> <p>The following priority pollutant total metals shall also be monitored using EPA approved methods found in Table IB of the current version of 40 CFR pt. 136: antimony, arsenic, beryllium, cadmium, chromium, copper, lead, nickel, selenium, silver, thallium, and zinc. In addition, the Permittee shall monitor for total cyanide, total phenolic compounds, and hardness (total as CaCO₃) using methods approved in the most recent update of 40 CFR pt. 136.</p> <p>Total mercury shall be monitored by EPA method 1631E or the most recent update to this method, if not already required by the permit.</p> <p>Total cyanide shall be monitored to the free cyanide water quality standard.</p> <p>The chromium reporting limit shall meet the chromium +6 water quality standard. [Minn. R. 7001]</p>
Chronic Toxicity Requirements		
	5.3.18	Definitions. [Minn. R. 7001]

5.3.19	"Chronic Whole Effluent Toxicity (WET) Test" is a static renewal test conducted on an exponentially diluted series of effluent. The purpose is to calculate appropriate biological effect endpoints (NOEC or IC25), specified in the referenced chronic manual. A statistical effect level less than the Receiving Water Concentration (RWC) constitutes a positive test for chronic toxicity. The RWC equals the 7% effluent concentration or 15.3 TUC. [State Definitions]
5.3.20	"Chronic toxic unit (TUC)" is the reciprocal of the effluent dilution that causes no unacceptable effect on the test organisms by the end of the chronic exposure period. For example, a TUC equals $[\text{7Q10 flow (mgd)} + \text{effluent average dry weather flow (mgd)}] / [\text{effluent average dry weather flow (mgd)}]$. [State Definitions]
5.3.21	"Test" refers to an individual species. [State Definitions]
5.3.22	"Test Battery" consists of WET testing of each species with each specified chronic test. For chronic WET testing, all test species includes fathead minnows and Ceriodaphnia dubia. [State Definitions]
5.3.23	General Requirements. [Minn. R. 7001]
5.3.24	This permit does not include a chronic WET limit; however, the facility has a WET monitoring requirement and is required to conduct chronic toxicity tests from outfall Station SD 001. Results of chronic toxicity tests will be evaluated against a monitoring threshold value of 15.3 TUC. [Minn. R. 7052, Minn. R. 7053]
5.3.25	The Permittee shall submit annual chronic toxicity test battery results : Due 180 calendar days after Permit Issuance Date annually thereafter. [Minn. R. 7001]
5.3.26	Additional WET tests are required for each year that exceeds the five-year permit cycle if the permit is not immediately reissued after permit expiration. The WET testing results are due on the same date as the original requirement, annually, until the permit is reissued. [Minn. R. 7001]
5.3.27	Any test that exceeds 15.3 TUC shall be re-tested according to the Positive Toxicity Results requirement(s) that follow to determine if toxicity is still present above 15.3 TUC (RWC<7%). [Minn. R. 7001]
5.3.28	Species and Procedural Requirements. [Minn. R. 7001]
5.3.29	Tests shall be conducted in accordance with procedures outlined in EPA-821-R-02-013 Short-term Methods for Measuring the Chronic Toxicity of Effluents and Receiving Waters to Freshwater Organisms - Fourth Edition (Chronic Manual) and any revisions to the Chronic Manual. [Minn. R. 7001]
5.3.30	Any test that begins with an effluent sample that is equal to or exceeds a total ammonia concentration of 5.0 mg/L may use the carbon dioxide-controlled atmosphere technique to control pH drift. [Minn. R. 7001]
5.3.31	Test organisms for each test battery shall include the fathead minnow (Pimephales promelas)-Method 1000.0 and Ceriodaphnia dubia-Method 1002.0 or any updates to these methods. [Minn. R. 7001]
5.3.32	Static renewal chronic serial dilution tests of the effluent shall consist of a control, 6, 12, 25, 50, and 100% effluent. [Minn. R. 7001]
5.3.33	All effluent samples shall be flow proportioned 24-hour composite samples. Test solutions shall be renewed daily. Testing of the effluent shall begin within 36 hours of sample collection. Receiving water collected outside of the influence of discharge or synthetic water provided by the laboratory shall be used for dilution and controls. [Minn. R. 7001]
5.3.34	Any other circumstances not addressed in the previous requirements or that require deviation from that specified in the previous requirements shall first be approved by the MPCA. [Minn. R. 7001]
5.3.35	Quality Control (QC) and Report Submittals. [Minn. R. 7001]
5.3.36	Any test that does not meet quality control measures or results which the Permittee believes reflect an artifact of testing (i.e. poor control results) shall be repeated within two weeks of the notification from the lab regarding the test sample results. The chronic WET report and QC reports shall contain information consistent with the report preparation section of the Chronic Manual. The MPCA shall make the final determination regarding test validity. [Minn. R. 7001]
5.3.37	Positive Toxicity Result for WET. [Minn. R. 7001]
5.3.38	Should a test exceed 15.3 TUC for WET based on results from the most sensitive test species, the Permittee shall conduct two repeat test batteries on all species. The repeat tests are to be completed within 45 days after completion of the positive test. These tests are used to determine if toxicity exceeding 15.3 TUC remains present for any test species. [Minn. R. 7001]
5.3.39	Repeat Testing Results. [Minn. R. 7001]

	5.3.40	Negative Retests. If no toxicity is present above 15.3 TUC for any test species in both retests, the Permittee shall return to the test frequency specified by the permit. [Minn. R. 7001]
	5.3.41	Positive Retests. If toxicity is present above 15.3 TUC for any test species in either retests, the Permittee shall submit a plan for conducting a Toxicity Reduction Evaluation (TRE) for MPCA review and approval. [Minn. R. 7001]
	5.3.42	TRE Requirements. [Minn. R. 7001]
	5.3.43	<p>The TRE shall be submitted within 60 days after the toxicity discovery date and include a Facility Performance Review. Upon approval of the TRE, the Permittee shall implement the TRE or subsequent amendments in its entirety. Any violations of the TRE are violations of this permit.</p> <p>In addition, quarterly reports starting from the date of the TRE submittal are required. The quarterly reports shall include, but are not limited to, a complete description of all progress made towards the identification of the source(s) of toxicity, and the Permittee's plans for the removal of the toxicity. The TRE shall be consistent with the Chronic Manual or subsequent procedures approved by the MPCA in attempting to identify and remove the source of the toxicity. Routinely scheduled chronic toxicity test batteries required in this permit shall remain in effect throughout the permit cycle.</p> <p>The Permittee must submit a request to discontinue the TRE for MPCA review upon conclusion of the TRE requirements. If the MPCA discontinues the TRE, the permit may be modified to set conditions to be met by the Permittee based on the TRE results. If the MPCA continues the TRE, the Permittee shall continue to implement the approved conditions of the TRE. [Minn. R. 7001]</p>
	5.3.44	Following successful completion of the TRE, the Permittee shall conduct semi-annual testing for the next five-year permit cycle. [Minn. R. 7001]
	5.3.45	WET Data and Test Acceptability Criteria (TAC) Submittal. [Minn. R. 7001]
	5.3.46	<p>All WET test data and TAC must be submitted to the MPCA by the dates required by this section of the permit using both the MPCA Ceriodaphnia dubia Chronic Toxicity Test Report and the MPCA Fathead Minnow Chronic Toxicity Test Report found on the MPCA website at https://www.pca.state.mn.us/business-with-us/step-4-create-swppp-choose-bmps.</p> <p>Data not submitted on the correct form(s), or submitted incomplete, will be returned to the Permittee and deemed incomplete until adequately submitted on the designated form(s). These are legal forms and must be signed and dated by the Permittee. [Minn. R. 7001]</p>
	5.3.47	Potential Permit Modifications. [Minn. R. 7001]
	5.3.48	The permit may be modified during a permit cycle to include additional toxicity testing and/or a WET limit based on the WET testing results. [Minn. R. 7001]
		Facility Specific Requirements
	5.4.53	The permit includes a proposed monthly total phosphorus water quality based effluent limit (WQBEL) kilograms per day (kg/day), June - September, to protect for eutrophication impairments in the Crow River and is consistent with river eutrophication standards (RES). The WQBEL of 3.5 kg/day is based off a five-year long-term average wasteload allocation (WLA) of 1.7 kg/day, June-September. The long-term average WLA of 1.7 kg/day is based on achieving RES 125 µg/L in the Crow River. The MPCA projects that by complying with the 3.5 kg/day monthly limit, the facility will have to average 1.7 kg/day, June-September, over a five-year/long-term period. After the five year permit cycle, MPCA will evaluate the facility's discharge and the downstream water quality. And if necessary, adjust the facility's 3.5 kg/day monthly average limit down to ensure that the long-term average WLA of 1.7 kg/day is achieved during the June-September effective period. [Minn. R. 7001]
WS 001	Influent Waste	
		Waste Stream: Class A Major Facility Influent Requirements

	5.5.1	The Permittee shall submit a monthly DMR : Due by 21 days after the end of each calendar month following permit issuance. [Minn. R. 7001.0150, subp. 2(B)]
	5.5.2	Sampling Location. [Minn. R. 7001.0150, subp. 2(B)]
	5.5.3	Samples for Station WS 001 shall be collected at a point representative of the total influent flow into the system. [Minn. R. 7001.0150, subp. 2(B)]
MN0064190	Otsego East WWTF	
		Surface Discharge Station General Requirements
	5.6.1	Surface Discharge Prohibitions. [Minn. R. 7001]
	5.6.2	Floating solids or visible foam shall not be discharged in other than trace amounts. [Minn. R. 7001]
	5.6.3	Oil or other substances shall not be discharged in amounts that create a visible color film. [Minn. R. 7001]
	5.6.4	The Permittee shall install and maintain outlet protection measures at the discharge stations to prevent erosion. [Minn. R. 7001]
	5.6.5	Winter Sampling Conditions. [Minn. R. 7001]
	5.6.6	The Permittee shall sample flows at the designated monitoring stations including when this requires removing ice to sample the water. If the station is completely frozen throughout a designated sampling month or if unsafe ice conditions exist, the Permittee shall check the "No Discharge/No Flow" box on the eDMR and note the ice conditions in the comments on the eDMR. [Minn. R. 7001]
	5.6.7	Chlorine Addition Requirements. [Minn. R. 7001]
	5.6.8	If chlorine is added for any purpose, the Permittee shall monitor the discharge for Total Residual Chlorine (TRC) once per day during chlorine usage. The Permittee shall report the monitoring data on the Sample Values and eDMR in months monitoring is required. If chlorine is added for any purpose outside of the effective period listed in the Limits and Monitoring section of the permit, the data should be submitted as a comment on that month's eDMR. The discharge shall not exceed a 0.038 mg/L TRC limit. [Minn. R. 7001]
	5.6.9	Sampling Collection and Reporting. [Minn. R. 7001]
	5.6.10	The Permittee shall submit monitoring results in accordance with the Limits and Monitoring requirements for this station. If conditions are such that no sample can be acquired, the Permittee shall check "No Discharge/No Flow" on the eDMR and shall add a comment to the eDMR detailing why the sample was not collected. [Minn. R. 7001.0150, subp. 2(B)]
	5.6.11	Mercury Limits and Monitoring Requirements. [Minn. R. 7001]
	5.6.12	The Permittee is required to sample for total suspended solids (mercury grab sample) at the same time that total mercury and dissolved mercury samples are taken. [Minn. R. 7001]
	5.6.13	Total and dissolved mercury samples shall be grab samples and shall be analyzed using the most recent revisions of EPA Methods 1631 and 1669. The Permittee is authorized to use another mercury analytical method that has a reportable level of <0.5 ng/L which allows for low-level sample characterization as long as the method is approved by the EPA and certified by an MPCA accreditation body. [Minn. R. 7001]
	5.6.14	Effluent monitoring for mercury with a frequency of twice per month and an effective period of Jan, Mar, May, Jul, Sep, Nov are to be taken twice per month during the months of January, March, May, July, September, and November. [Minn. R. 7001]
	5.6.15	Nitrogen Limits and Monitoring Requirements. [Minn. R. 7001]
	5.6.16	"Total Nitrogen" with a sample type of "Calculation" is to be reported as the summation of the total Kjeldahl nitrogen and total nitrite plus nitrate nitrogen values. [Minn. R. 7001]
	5.6.17	Nitrogen Reduction Strategy Optimization Incentive (Voluntary). [Minn. R. 7001]

5.6.18	<p>A 10 mg/L total nitrogen State Discharge Restriction (SDR) is being proposed for all major municipal wastewater treatment facilities, high concentration minor municipal wastewater treatment facilities, and high concentration industrial dischargers in a MPCA nitrate rulemaking effort. To encourage wastewater treatment facilities to start making achievable nitrogen reductions as soon as possible, the MPCA is proposing in the rulemaking to defer applicability of the SDR limit for one permit cycle for Permittees that have optimized their existing wastewater treatment operations and are able to meet a 15 mg/L total nitrogen limit based on a 12-Month Moving Average for at least 12 months prior to the adoption of a SDR.</p> <p>Note the following:</p> <p>A. The proposed SDR limit is applicable for all major municipal, high concentration minor municipal, and high concentration industrial dischargers. If the Permittee is not currently classified as a major facility but may be prior to SDR adoption, the Permittee may still have the opportunity to participate in this optimization incentive.</p> <p>B. This optimization incentive is dependent on successful rulemaking efforts. If the entire rulemaking or the optimization incentive-portion of the rulemaking are not successful, the SDR limit deferral will not be applicable.</p> <p>C. Once facilities have optimized to reduce their nitrogen concentrations, they must continue operating the facilities in accordance with the optimization efforts.</p> <p>Refer to the accompanying permit documents for additional information regarding the optimization incentive. [Minn. R. 7001]</p>
5.6.19	<p>Phosphorus Limit Types and Calculations. See the Limits and Monitoring section of this permit to determine which, if any, applies. [Minn. R. 7001]</p>
5.6.20	<p>"12-Month Moving Average" is a rolling average. For the first 11 months after this limit becomes effective, add all of the monthly average values starting with the first full month the final limit became effective and divide by the number of months since that same date. This value should be reported on the eDMR in the 12-Month Moving Average field.</p> <p>If using the eDMR calculator tool, replace the calculated value with the value calculated above as the eDMR calculated value will not be correct until 12 months of data are collected following permit reissuance. Starting the 12th month after this limit became effective and thereafter, add all of the monthly average values during the last 12 months and divide by 12. Starting the 12th month after this limit became effective and thereafter, the eDMR calculator tool will provide the correct value for this limit. [Minn. R. 7001]</p>
5.6.21	<p>"12-Month Moving Total" is a rolling total. For the first 11 months after this limit becomes effective, report the mass phosphorus discharged by calculating each month's kg/month, then adding each month's kg/month from the first month the new limit is effective through the 11th month after this limit became effective. This value should be reported on the eDMR in the 12-Month Moving Total field.</p> <p>If using the eDMR calculator tool, replace the calculated value with the value calculated above as the eDMR calculated value will not be correct until 12 months of data are collected following permit reissuance. Starting the 12th month after this limit became effective and thereafter, calculate each kg/month then add all of the monthly values during the last twelve months, starting with the monthly total for the month of the current reporting period. Calculate kg/month for each month by multiplying the total volume of effluent flow (MG) x the monthly average concentration x 3.785 conversion factor to get kg/month. Starting the 12th month after this limit became effective and thereafter, the eDMR calculator tool will provide the correct value for this limit. [Minn. R. 7001]</p>
	<p>Waste Stream Station General Requirements</p>
5.7.25	<p>Sampling Collection and Reporting. [Minn. R. 7001]</p>

5.7.26	The Permittee shall submit monitoring results in accordance with the limits and monitoring requirements for this station. If conditions are such that no sample can be acquired, the Permittee shall report "No Flow" or "No Discharge" on Discharge Monitoring Report (DMR) and shall add a Comments attachment to the DMR detailing why the sample was not collected. [Minn. R. 7001.0150, Subp 2(B)]
5.7.27	Mercury Limits and Monitoring Requirements. [Minn. R. 7001]
5.7.28	Total mercury samples shall be grab samples and shall be analyzed using the most recent revisions of EPA Methods 1631 and 1669. The Permittee is authorized to use another mercury analytical method that has a reportable level that allows for low-level sample characterization as long as the method is approved by the EPA and certified by a MPCA accreditation body. [Minn. R. 7001]
5.7.29	Influent samples for mercury monitoring with a frequency of twice per month and an effective period of Jan, Mar, May, Jul, Sep, Nov are to be taken at a time similar to that of effluent monitoring, if possible; twice per month during the months of January, March, May, July, September, and November. [Minn. R. 7001]
5.7.30	Nitrogen Limits and Monitoring Requirements. [Minn. R. 7001]
5.7.31	"Total Nitrogen" with a sample type of "Calculation" is to be reported as the summation of the total Kjeldahl nitrogen and total nitrite plus nitrate nitrogen values. [Minn. R. 7001]
	Special Requirements
5.8.35	Limits and Monitoring Submittal Phases. [Minn. R. 7001]
5.8.36	Phase 1: Applies to the existing facility. Phase 1 is effective upon permit issuance. Phase 2: Applies to the proposed facility as described in the Facility Description. Phase 2 limits become effective 90 days after initiation of operation of the proposed facility. Limits and monitoring and report requirements without a phase assigned are effective from permit issuance throughout the life of the permit. [Minn. R. 7001]
5.8.37	Drinking Water Intake Requirements. [Minn. R. 7001]
5.8.38	This facility is upstream of a drinking water in-take and therefore needs to meet the fecal coliform limit by disinfection prior to discharge, year-round. The MPCA also recommends notifying all downstream users in the event of a spill, release or discharge that could endanger human health, public drinking water supplies, recreational users, or the environment. [Minn. R. 7001]
	Construction Schedule
5.9.49	Definitions. [Minn. R. 7001]
5.9.50	"Initiation of operation" means the date the MPCA determines all components of the wastewater treatment system are complete and functioning and the project begins operating for the purposes for which it was planned, designed, and built. [Minn. R. 7001]
5.9.51	"Completion of construction" means all the construction is complete except for minor weather-related components and conforms to the approved plans and specifications and change orders. [Minn. R. 7001]
5.9.52	"Notice to proceed" means a written notice given by the Permittee to the contractor that affixes the contract effective date and the date that the contractor begins performing the work specified in the contract documents. [Minn. R. 7001]
5.9.53	Schedule for Construction. [Minn. R. 7001]
5.9.54	By 90 days prior to commencement of construction, the Permittee shall submit Plans and Specifications for MPCA review and approval. [Minn. R. 7001]
5.9.55	Submit Notice to Proceed. [Minn. R. 7001]
5.9.56	The Permittee shall submit a copy of the Notice to Proceed to the MPCA within 14 days of its execution. [Minn. R. 7001]

5.9.57	Submit Verification of Certified Operator and O&M Manual. [Minn. R. 7001]
5.9.58	The Permittee shall notify the MPCA in writing at least 60 days before the planned initiation of operation of the new or upgraded facility that it has employed a wastewater treatment facility operator, certified for the classification of the treatment system (according to Minn. R. ch. 9400), that is directly responsible for the operation of the system. The Permittee shall also submit an operation and maintenance (O&M) manual or a maintenance plan or a certificate of completion of an operation and maintenance manual. [Minn. R. 7001]
5.9.59	Submit Notice of Intent to Initiate Operation. [Minn. R. 7001]
5.9.60	The Permittee shall notify the MPCA in writing at least 14 days before the planned initiation of operation date. Following MPCA staff concurrence that the facility is adequately prepared, MPCA staff will notify the Permittee that it may initiate operation of the new or upgraded facility. [Minn. R. 7001]
5.9.61	Submit Initiation of Operation Date. [Minn. R. 7001]
5.9.62	The Permittee shall notify the MPCA in writing within 14 days after the actual initiation of operation date. [Minn. R. 7001]
5.9.63	Attain Compliance with Final (Phase 2) Limits. [Minn. R. 7001]
5.9.64	The Permittee shall comply with all permit requirements and attain final limits (Phase 2 limits) within 90 days of the Initiation of Operation date. [Minn. R. 7001]
5.9.65	Submit Notice to Complete Construction. [Minn. R. 7001]
5.9.66	The Permittee shall notify the MPCA in writing at least 14 days before the planned completion of construction date. The MPCA may complete a final inspection. [Minn. R. 7001]
5.9.67	Submit Final Technical Documents. [Minn. R. 7001]
5.9.68	The Permittee shall submit the following to the MPCA within one year after the initiation of operation date: A. A certification on a form specified, or approved by, the MPCA that is signed by a professional engineer registered in the state of Minnesota stating that the project meets the performance standards; B. A revised operation and maintenance manual or a maintenance plan; or a certificate of completion of an operation and maintenance manual on a form prescribed by the MPCA. At a minimum, this plan shall include a detailed discussion of operation and controls, maintenance, sampling and analysis, problem mitigation, VOC management, personnel records and reporting, and safety. This plan shall be maintained and updated regularly and made available to MPCA staff upon request; C. One copy of "as-built" plans and specifications, also known as record drawings, shall be submitted in a format approved by the MPCA. The factsheet titled Wastewater Treatment Facility Construction Record Documents, As-built Submittal Requirements contains specific information regarding the required format of the submittal. The factsheet can be found on the MPCA's website at https://www.pca.state.mn.us/business-with-us/engineering-and-technical-information-for-construction-or-expansion . [Minn. R. 7001]
	Nitrogen Management Plan - Enhanced
5.10.81	This permit requires the development of an Enhanced Nitrogen Management Plan (NMP). Enhanced NMPs are required for facilities discharging upstream of an impaired waterbody with nitrate as a stressor and are causing, or have a reasonable potential to cause or contribute to, nitrate concentrations contributing to biological stressors to aquatic organisms in these waterbodies. Specific nitrogen monitoring requirements are detailed in the limits and monitoring section of this permit. Information gained through the Enhanced NMP process can be used to reduce influent and effluent nitrogen concentrations and loads. The Permittee shall consider selecting activities based on the potential of those activities to reduce influent and effluent nitrogen loadings as part of its nitrogen management strategy. [Minn. R. 7001]
5.10.82	The Permittee shall submit a nitrogen management plan : Due by 18 months after permit issuance. [Minn. R. 7001]

5.10.83	<p>The intent of the Enhanced NMP is to:</p> <p>A. Establish source reduction and treatment facility optimization activities, operational improvements, and wastewater treatment facility modifications that will reduce influent and/or effluent nitrogen loadings; and</p> <p>B. Evaluate treatment facility optimization strategies or modifications needed to achieve effluent denitrification to levels sufficient for the protection of aquatic organisms in downstream waterbodies. [Minn. R. 7001]</p>
5.10.84	<p>The Permittee shall implement the Enhanced NMP immediately upon submittal to the MPCA. [Minn. R. 7001]</p>
5.10.85	<p>The Enhanced NMP shall include, but is not limited to, the following:</p> <p>A. Construct a plan to implement nitrogen management and reduction measures throughout the permit term, including any period following permit expiration but prior to permit reissuance or permit termination.</p> <p>i. Summarize nitrogen influent and effluent concentrations and digester supernatant and other high strength return flows or waste streams (i.e., septage), if applicable, and monitoring data using the most recent five years of monitoring data, if available;</p> <p>ii. Evaluate past and present wastewater treatment facility operations to determine those operating procedures that maximize nitrogen removal;</p> <p>iii. Identify specific actions that the Permittee will take to reduce or minimize influent nitrogen sources by working with the influent contributors;</p> <p>iv. Analyze expected reductions in nitrogen achieved from actions taken by influent contributors;</p> <p>v. Identify specific actions taken to implement facility optimization/changes to improve nitrogen removal; and</p> <p>vi. Summarize any nitrogen management activities implemented during the last five years.</p> <p>B. Construct a plan to implement nitrogen management and reduction measures during the next five years.</p> <p>i. Wastewater treatment facility influent reduction measures.</p> <p>a. Evaluate the nitrogen reduction potential of users or classes of users with high nitrogen concentrations and/or loading;</p> <p>b. Identify existing and potential sources of excess nitrogen concentrations and/or loading to the facility. As appropriate for the facility, the Permittee shall consider residential, institutional, municipal, and commercial sources (i.e., food processing, fertilizer production, metal finishing, and other industries or commercial processes with the potential for significant nitrogen contributions). Consideration should also be given to nitrogen sources recirculated within the wastewater treatment facility such biosolids supernatant return flows;</p> <p>c. Determine whether known sources of elevated nitrogen concentrations or loadings have adopted or can adopt nitrogen minimization and water conservation plans;</p> <p>d. When necessary, require users with excessive nitrogen concentrations and/or loading users to submit NMPs that include identification of user specific opportunities to reduce nitrogen in their discharges;</p> <p>e. Evaluate whether local limits on influent sources of excessive nitrogen are needed or whether any existing local limits are appropriate; and</p> <p>f. Analyze inflow and infiltration of groundwater and stormwater into the collection system and impacts on the facility's hydraulic capacity. [Minn. R. 7001]</p>

5.10.86	(continued) ii. Wastewater treatment facility effluent reduction measures. a. Evaluate past and present wastewater treatment facility operations to determine those operating procedures that result in nitrogen removal to the fullest practicable extent. The evaluation shall include, but not be limited to, the following: 1. Develop and implement a process control monitoring plan; 2. Evaluate treatment capacity and optimization alternatives for existing treatment processes; 3. Assess side stream loading and reductions options; 4. Analyze inflow and infiltration of groundwater and stormwater into the collection system and impacts on the facility's effluent nitrogen loading and removal efficiency; 5. Evaluate alternative treatment methods; and 6. Evaluate treatment facility optimization strategies or modifications needed to achieve a 12-month moving average total nitrogen effluent concentration of 10 mg/L. C. If applicable, nitrogen effluent concentration and loading progress report. i. Identify all progress made through implementation of the Enhanced NMP; and ii. Evaluate influent and effluent nitrogen data since permit issuance and a discussion on removal efficiencies. [Minn. R. 7001]
5.10.87	NMP guidance can be found on the MPCA's website at https://www.pca.state.mn.us/business-with-us/nitrogen-management-plans . [Minn. R. 7001]
	Mechanical System
5.11.91	Bypass Structures. [Minn. R. 7001]
5.11.92	All structures capable of bypassing the treatment system shall be manually controlled and kept locked at all times. [Minn. R. 7001.0030]
5.11.93	Sanitary Sewer Extension Permit. [Minn. R. 7001]
5.11.94	The Permittee may be required to obtain a sanitary sewer extension permit from the MPCA for any addition, extension, or replacement to the sanitary sewer. If a sanitary sewer extension permit is required, construction may not begin until plans and specifications have been submitted and a written permit is granted except as allowed in Minn. Stat. 115.07, subd. 3b. [Minn. R. 7001.0020]
5.11.95	Operator Certification. [Minn. R. 7001]
5.11.96	The Permittee shall provide a Class A state certified operator who maintains direct responsibility of the operation, maintenance, and testing functions required to ensure compliance with the terms and conditions of this permit. [Minn. R. 9400]
5.11.97	The Permittee shall provide the appropriate number of operators with a Type IV certification to be responsible for the land application of biosolids or semisolids from commercial or industrial operations. [Minn. R. 7048]
5.11.98	If the Permittee chooses to meet operator certification requirements through a contractual agreement, the Permittee shall provide a copy of the contract to the MPCA, WQ Submittals Center. The contract shall include: A. The certified operator's name, certificate number, company name (if appropriate), and the period covered by the contract and provisions for renewal; B. The duties and responsibilities of the certified operator; C. The duties and responsibilities of the Permittee; and D. Provisions for notifying the MPCA 30 days in advance of termination if the contract is terminated prior to the expiration date. [Minn. R. 9400]
5.11.99	The Permittee shall notify the MPCA within 30 days of a change in operator certification or contract status. [Minn. R. 9400]
	Pretreatment: Nondelegated Requirements
5.12.103	Definitions. [Minn. R. 7049]

5.12.104	"Individual Control Mechanism" means a document, such as an agreement or permit, which imposes limitations or requirements on an individual industrial user of the publicly owned treatment works (POTW). [Minn. R. 7049]
5.12.105	<p>"Significant Industrial User" (SIU) means any industrial user that:</p> <ul style="list-style-type: none"> A. Is subject to Categorical Pretreatment Standards, as defined in Minn. R. 7049.0120, subp. 5; B. Discharges 25,000 gallons per day or more of process wastewater, excluding sanitary, noncontact cooling, or boiler blowdown wastewater, to the POTW; C. Contributes a process wastewater containing five percent or more of the flow or load of any pollutant of concern to the POTW; or D. Is designated as significant by the Permittee or the MPCA on the basis that the industrial user has a reasonable potential to adversely impact the POTW's operation or violate any pretreatment standard or requirement. [Minn. R. 7049]
5.12.106	Permittee Responsibility to Control Users. [Minn. R. 7049]
5.12.107	It is the Permittee's responsibility to regulate the discharge from users of its POTW. The Permittee shall prevent any pass through of pollutants or any inhibition or disruption of the Permittee's POTW, its treatment processes, or its sludge processes or disposal that contribute to the violation of the conditions of this permit or any federal or state law or regulation limiting the release of pollutants from the POTW. [Minn. R. 7049]
5.12.108	<p>The Permittee shall prohibit the discharge of the following to its POTW:</p> <ul style="list-style-type: none"> A. Pollutants that create a fire or explosion hazard, including any discharge with a flash point less than 60 degrees C (140 degrees F); B. Pollutants that will cause corrosive structural damage to the POTW, including any waste stream with a pH of less than 5.0; C. Solid or viscous pollutants which would obstruct flow; D. Any pollutant, including oxygen-demanding pollutants such as biochemical oxygen demand, released at a flow rate or pollutant concentration that will cause interference or pass-through; E. Heat that would inhibit biological activity, including any discharge that would cause the temperature of the waste stream at the POTW treatment plant headwork's to exceed 40 degrees C (104 degrees F); F. Petroleum oil, nonbiodegradable cutting oil, or products of mineral oil origin in amounts that would cause interference or pass-through; and G. Pollutants that produce toxic gases, vapors, or fumes that may endanger the health or safety of workers. [Minn. R. 7049]
5.12.109	The Permittee shall prohibit new discharges of non-contact cooling waters unless there is no cost effective alternative. Existing discharges of non-contact cooling water to the Permittee's POTW shall be eliminated, where elimination is cost effective, or where an infiltration/inflow analysis and sewer system evaluation survey indicates the need for such removal. [Minn. R. 7049]
5.12.110	If the Permittee accepts trucked-in wastes, the Permittee shall evaluate the trucked-in wastes prior to acceptance in the same manner as it monitors sewered wastes. The Permittee shall accept trucked-in wastes only at specifically designated points. [Minn. R. 7049]
5.12.111	<p>Pollutant of concern means a pollutant that is or may be discharged by an industrial user that is or reasonably should be of concern on the basis that it may cause the Permittee to violate any permit limits on the release of pollutants. The following pollutants shall be evaluated to determine if they should be pollutants of concern:</p> <ul style="list-style-type: none"> A. Pollutants limited in this permit; B. Pollutants for which monitoring is required in this permit; C. Pollutants that are likely to cause inhibition of the Permittee's POTW; D. Pollutants which may interfere with sludge disposal; and E. Pollutants for which the Permittee's POTW has limited capacity. [Minn. R. 7049]
5.12.112	Control of Significant Industrial Users. [Minn. R. 7049]

5.12.113	The Permittee shall impose pretreatment requirements on SIUs to ensure compliance with all applicable effluent limitations and other requirements set forth in this permit or any federal or state law or regulation limiting the release of pollutants from the POTW. These requirements shall be applied to SIUs by means of an individual control mechanism. [Minn. R. 7049]
5.12.114	The Permittee shall not knowingly enter into an individual control mechanism with any user that would allow the user to contribute an amount or strength of wastewater that would cause violation of any limitation or requirement in the permit, or any applicable federal, state, or local law or regulation. [Minn. R. 7049]
5.12.115	Monitoring of Significant Industrial Users. [Minn. R. 7049]
5.12.116	The Permittee shall obtain specific information from SIUs on the quality and quantity of the SIU's discharges to the Permittee's POTW. Except where specifically requested by the Permittee and approved by the MPCA, this information shall be obtained by means of representative monitoring conducted by the Permittee or by the SIU under requirements imposed by the Permittee in the SIU's individual control mechanism. Monitoring performed to comply with this requirement shall include all pollutants for which the SIU is significant and shall be done at a frequency commensurate with the significance of the SIU. [Minn. R. 7049]
5.12.117	Reporting and Notifications. [Minn. R. 7049]
5.12.118	The Permittee shall submit a pretreatment annual report : Due by 31 days after the end of each calendar year following permit issuance if a SIU discharges to the POTW during a given calendar year. [Minn. R. 7049]
5.12.119	The Permittee shall submit the Pretreatment Annual Report found on the MPCA's website at https://www.pca.state.mn.us/business-with-us/wastewater-pretreatment or shall provide equivalent information. [Minn. R. 7049]
5.12.120	The Permittee shall submit the Pretreatment Annual Report to the MPCA, WQ Submittals Center. [Minn. R. 7049]
5.12.121	The Permittee shall notify the MPCA in writing of any of the following: <ul style="list-style-type: none"> A. Any SIU of the Permittee's POTW which has not been previously disclosed to the MPCA; B. Anticipated or actual changes in the volume or quality of discharge by an industrial user that could result in the industrial user becoming an SIU as defined in this section; or C. Anticipated or actual changes in the volume or quality of discharges by a SIU that would require changes to the SIU's required local limits. <p>This notification shall be submitted within 30 days of identifying the industrial user as a SIU. Where changes are proposed, they shall be submitted prior to changes being made. [Minn. R. 7049]</p>
5.12.122	Upon notifying the MPCA of a SIU or change in a SIU discharge as required above, the Permittee shall submit the following information using the forms found on the MPCA's website at https://www.pca.state.mn.us/water/wastewater-pretreatment or in a comparable format: <ul style="list-style-type: none"> A. The identity of the SIU and a description of the SIU's operation and process; B. A characterization of the SIU's discharge; C. The required local limits that will be imposed on the SIU; D. A technical justification of the required local limits; and E. A plan for monitoring the SIU which is consistent with monitoring requirements in this section. [Minn. R. 7049]
5.12.123	In addition, the Permittee shall, upon request, submit the following to the MPCA for approval: <ul style="list-style-type: none"> A. Additional information on the SIU, its processes, and discharge; B. A copy of the individual control mechanism used to control the SIU; C. The Permittee's legal authority to be used for regulating the SIU; and D. The Permittee's procedures for enforcing the requirements imposed on the SIU. [Minn. R. 7049]
5.12.124	The Permittee shall notify the MPCA of any of its industrial users that may be subject to National Categorical Pretreatment Standards. [Minn. R. 7049]

5.12.125	This permit may be modified in accordance with Minn. R. ch. 7001 to require development of a pretreatment program approvable under the Federal General Pretreatment Regulation (40 CFR 403). [Minn. R. 7049]
	Biosolids: Exceptional Quality
5.13.126	Authorization. [Minn. R. 7041]
5.13.127	This permit authorizes the Permittee to prepare, store, and distribute Class B domestic wastewater treatment biosolids and Exceptional Quality Biosolids to the land in accordance with the provisions in this section and Minn. R. ch. 7041. [Minn. R. 7041]
5.13.128	Permittees who prepare bulk biosolids shall obtain approval of the sites on which bulk biosolids are applied before they are applied unless they are Exceptional Quality Biosolids. Site application procedures are set forth in Minn. R. 7041.0800. [Minn. R. 7041.0600, Minn. R. 7041.0800]
5.13.129	Compliance Responsibility. [Minn. R. 7041]
5.13.130	The Permittee is responsible for ensuring that the applicable requirements in this section and Minn. R. ch. 7041 are met when biosolids are prepared, distributed, and/or applied to the land. [Minn. R. 7041]
5.13.131	A Type IV certified operator must oversee the preparation of the Exceptional Quality Biosolids. [Minn. R. 7041.0440, subp. 2(B), Minn. R. 7048.0500, subp. 1]
5.13.132	The Permittee may not blend the Exceptional Quality Biosolids produced by the process described in this permit with other materials before distributing them to other persons. [Minn. R. 7041]
5.13.133	Exceptional Quality Biosolids produced by the process described in this permit are not subject to the general requirements in Minn. R. 7041.1000 or the management practices in Minn. R. 7041.1200, with the exception of Minn. R. 7041.1200, subp. 8, items D and E field storage requirements which do apply as noted below: D. Long-term storage of Exceptional Quality Biosolids shall not take place within 1,000 feet of any downgradient surface waters and wetlands listed in subp. 3, item B, tile inlets, or sinkholes unless measures are taken to control runoff in which case the separation distance may be reduced to 200 feet; and E. Long-term storage of bulk Exceptional Quality Biosolids shall not be allowed on land with greater than a two percent slope. [Minn. R. 7041]
5.13.134	Long-term storage of Exceptional Quality Biosolids shall not exceed seven months on agricultural land, forest, or a reclamation site. [Minn. R. 7041]
5.13.135	Persons who prepare Exceptional Quality Biosolids shall provide the total nitrogen, phosphorus, and potassium content and the effective neutralizing power to the person who applies or distributes the Exceptional Quality Biosolids. This information shall be provided in writing. [Minn. R. 7041]
5.13.136	Notification Requirements. [Minn. R. 7041]
5.13.137	The Permittee shall provide information needed to comply with the biosolids requirements of Minn. R. ch. 7041 to others who prepare or use the biosolids in writing. [Minn. R. 7041]
5.13.138	The Permittee shall inform persons who receive the bulk Exceptional Quality Biosolids of the storage requirements in this section in writing. [Minn. R. 7041]
5.13.139	Pollutant Limits. [Minn. R. 7041]

5.13.140	<p>Biosolids which are applied to the land shall not exceed the ceiling concentrations in Table 1 and shall not be applied so that the cumulative amounts of pollutant in Table 2 are exceeded. Exceptional Quality Biosolids shall not exceed the ceiling concentration in Table 1 and shall meet the pollutant concentrations in Table 3.</p> <p>Table 1 Ceiling Concentrations (dry weight basis)</p> <p>Pollutant in units mg/kg Arsenic 75 Cadmium 85 Copper 4300 Lead 840 Mercury 57 Molybdenum 75 Nickel 420 Selenium 100 Zinc 7500</p> <p>Table 2 Cumulative Loading Limits</p> <p>Pollutant in units lbs/acre Arsenic 37 Cadmium 35 Copper 1339 Lead 268 Mercury 15 Molybdenum* Nickel 375 Selenium 89 Zinc 2500</p> <p>*The cumulative limit for molybdenum has not been established at the time of permit issuance</p> <p>Table 3 Pollutant Concentrations</p> <p>Pollutant in units mg/kg* Arsenic 41 Cadmium 39 Copper 1500 Lead 300 Mercury 17 Nickel 420 Selenium 100 Zinc 2800</p> <p>*On a dry weight basis, the arithmetic mean of all measurements taken during the month. [Minn. R. 7041.1100]</p>
5.13.141	Pathogen and Vector Attraction Reduction. [Minn. R. 7041]
5.13.142	Biosolids shall be processed, treated, or be incorporated or injected into the soil to meet one of the vector attraction reduction requirements in Minn. R. 7041.1400. [Minn. R. 7041.1400]
5.13.143	Biosolids shall be processed or treated by one of the alternatives in Minn. R. 7041.1300 to meet the Class A or Class B standards for the reduction of pathogens. When Class B biosolids are applied to the land, the site restrictions in Minn. R. 7041.1300 shall also be met. [Minn. R. 7041.1300]

5.13.144	<p>The minimum duration between application and harvest, grazing, or public access to areas where Class B biosolids have been applied to the land is as follows:</p> <p>A. 14 months for food crops whose harvested parts may touch the soil/biosolids mixture (such as melons, squash, tomatoes, etc.), when biosolids are surface applied, incorporated, or injected;</p> <p>B. 20 months or 38 months depending on the application method for food crops whose harvested parts grow in the soil (such as potatoes, carrots, onions, etc.). The 20-month time period is required when biosolids are surface applied or surface applied and incorporated after they have been on the soil surface for at least four months. The 38-month time period is required when the biosolids are injected or surface applied and incorporated within four months of application;</p> <p>C. 30 days for feed crops, other food crops (such as field corn, sweet corn, etc.), hay, or fiber crops when biosolids are surface applied, incorporated, or injected;</p> <p>D. 30 days for grazing of animals when biosolids are surface applied, incorporated, or injected; and</p> <p>E. One year where there is a high potential for public contact with the site (such as a reclamation site located in populated areas, a construction site located in a city, turf farms, plant nurseries, etc.) and 30 days where there is low potential for public contact (such as agricultural land, forest, a reclamation site located in an unpopulated area, etc.) when biosolids are surface applied, incorporated, or injected. [Minn. R. 7041.1300]</p>
5.13.145	<p>Exceptional Quality Biosolids are required to meet the Class A process standard in Minn. R. 7041.1300, subp. 2, item G(7) pasteurization or item H, Bioset process as approved by EPA as follows:</p> <p>For Pasteurization: The standard mode of operation is to maintain the temperature of the sewage sludge at 70 degrees Celsius or higher for 30 minutes or longer.</p> <p>For Bioset Process: The temperature can be reduced to 131 degrees F (55 degrees C) when the process solids are between 6 and 35% by weight and with a minimum ammonia-N concentration in the reactor discharge of 0.5 mg NH₃-N/g dry weight, monitored by EPA method 350.1 Revision 2, 1993 or EPA method 1690, Draft 2001 (EPA-821-R-01-009). Solids are mixed with calcium oxide, have a pH of equal or greater than 12 standard units and sulfamic acid must be mixed with the solids/quicklime mixture to maintain the temperature. If the minimum criteria cannot be met, then the parameters will be run according to the standard mode at 70C/30 min as described above. [Minn. R. 7041.1300, Subp.2(item G(7))and item H]</p>
5.13.146	<p>In addition to the Class A process defined in the requirement above, either the density of fecal coliform in the biosolids shall be less than 1000 MPN per gram of total solids (dry weight basis) or the density of Salmonella sp. bacteria in the biosolids shall be less than three MPN per four grams or total solids (dry weight basis) at the time the biosolids are applied to land, are prepared for sale or giveaway in a bag or other container for application to land, or when the biosolids or material derived from the biosolids is prepared to meet the requirements of Exceptional Quality Biosolids. [Minn. R. 7041.1300]</p>
5.13.147	<p>Exceptional Quality Biosolids are required to meet vector attraction reduction at the same time or after pathogen reduction is met by the option defined in Minn. R. 7041.1400, subp. 2, item F as follows:</p> <p>The pH of sewage sludge shall be raised to 12 or higher by alkali addition and, without the addition of more alkali, shall remain at 12 or higher for two hours and then at 11.5 or higher for an additional 22 hours. [Minn. R. 7041.1400, subp.2(item F)]</p>
5.13.148	<p>Management Practices. [Minn. R. 7041]</p>
5.13.149	<p>The management practices for the land application of biosolids are described in detail in Minn. R. 7041.1200 and shall be followed unless specified otherwise in a site approval letter or a permit issued by the MPCA. [Minn. R. 7041.1200]</p>

5.13.150	<p>Overall management requirements:</p> <p>A. Biosolids shall not be applied to the land if it is likely to adversely affect a threatened or endangered species listed under Section 4 of the Endangered Species Act or its designated critical habitat;</p> <p>B. Biosolids shall not be applied to flooded, frozen, or snow covered ground so that the biosolids enter wetlands or other waters of the state;</p> <p>C. Biosolids shall be applied at an agronomic rate unless specified otherwise by the MPCA in a permit; and</p> <p>D. Biosolids shall not be applied within 33 feet of a wetland or waters of the state unless specified otherwise by the MPCA in a permit. [Minn. R. 7041]</p>
5.13.151	<p>Monitoring Requirements. [Minn. R. 7041]</p>
5.13.152	<p>Representative samples of biosolids applied to the land shall be analyzed by methods specified in Minn. R. 7041.3200 for the following parameters: arsenic, cadmium, copper, lead, mercury, molybdenum, nickel, selenium, zinc, Kjeldahl nitrogen, ammonia nitrogen, total solids, volatile solids, phosphorus, potassium, and pH. [Minn. R. 7041]</p>
5.13.153	<p>At a minimum, biosolids shall be monitored at the frequencies specified in Table 3 for the parameters listed above, and any pathogen or vector attraction reduction requirements in Minn. R. 7041.1300 and 7041.1400 if used to determine compliance with those parts.</p> <p>Table 3 Minimum Sampling Frequencies</p> <p>Biosolids Applied* Biosolids Applied* Frequency (metric tons/365-day period) (tons/365-day period) (times/365-day period)</p> <p>>0 but <290 >0 but <320 1 >=290 but <1,500 >=320 but <1,650 4 >=1,500 but <15,000 >=1,650 but <16,500 6 >=15,000 >=16,500 12</p> <p>*Either the amount of bulk biosolids applied to the land or the amount of biosolids received by a person who prepares biosolids that are sold or given away in a bag or other container for application to the land (dry weight basis). [Minn. R. 7041.1500]</p>
5.13.154	<p>Increased sampling frequencies are specified for the parameters listed in Table 4. Sampling at a frequency at twice the minimum frequencies in Table 3 is required if concentrations listed in Table 4 are exceeded (based on the average of all analyses made during the previous cropping year).</p> <p>Table 4 Increased Frequency of Sampling</p> <p>Parameter in units mg/kg (dry weight basis)</p> <p>Arsenic 38 Cadmium 43 Copper 2150 Lead 420 Mercury 28 Molybdenum 38 Nickel 210 Selenium 50 Zinc 3750. [Minn. R. 7041.1500]</p>
5.13.155	<p>Records. [Minn. R. 7041]</p>
5.13.156	<p>The Permittee shall keep records of the information necessary to show compliance with pollutant concentrations and loadings, pathogen reduction requirements, vector attraction reduction requirements, and management practices as specified in Minn. R. 7041.1600, subp. 2 and/or 3, as applicable. [Minn. R. 7041.1600]</p>

5.13.157	Reporting Requirements. [Minn. R. 7041]
5.13.158	The Permittee shall submit a biosolids annual report : Due annually, by the 31st of December. [Minn. R. 7041]
5.13.159	The Permittee shall submit the Biosolids Annual Report found on the MPCA's website at https://www.pca.state.mn.us/business-with-us/wastewater-operator-resources or shall provide equivalent information in another MPCA approved format. The report shall include the requirements in Minn. R. 7041.1700. [Minn. R. 7041]
5.13.160	The Biosolids Annual Report shall be submitted by December 31 of each year for biosolids storage and/or transfer activities occurring during the cropping year previous to December 31. Cropping year means a year beginning on September 1 of the year prior to the growing season and ending August 31 the year the crop is harvested. For example, the 2019 cropping year began September 1, 2018 and ended August 31, 2019. [Minn. R. 7041]
5.13.161	The Biosolids Annual Report shall indicate whether or not biosolids were transferred and/or stored. If biosolids were transferred, the report shall describe: A. How much was transferred; B. Where it was transferred to; C. The name of the facility that accepted the transfer; and D. The contact person at that facility. [Minn. R. 7041]
5.13.162	For biosolids that are stored for more than two years, the Biosolids Annual Report shall also include the analytical data from the representative sample of the biosolids generated during the cropping year. [Minn. R. 7041]
5.13.163	The Permittee shall submit the Biosolids Annual Report to the MPCA, WQ Submittals Center. [Minn. R. 7041]
5.13.164	The Permittee shall notify the MPCA in writing when 90 percent or more of any of the cumulative pollutant loading rates listed for any land application sites has been reached for a site. [Minn. R. 7041]
	Total Facility Requirements (NPDES/SDS)
5.14.165	Definitions. Refer to the Permit User's Manual found on the MPCA's website at https://www.pca.state.mn.us/sites/default/files/wq-wwtp7-09.pdf for standard definitions. [Minn. R. 7001]
5.14.166	Incorporation by Reference. This permit incorporates the following applicable federal and state laws applicable to the Permittee and enforceable parts of this permit: 40 CFR pts. 122.41, 122.42, 136, 403 and 503; Minn. R. chs. 7001, 7041, 7045, 7050, 7052, 7053, 7060, and 7080; and Minn. Stat. chs. 115 and 116. [Minn. R. 7001]
5.14.167	Permittee Responsibility. The Permittee shall perform the actions or conduct the activity authorized by this permit in compliance with the conditions of the permit and, if required, in accordance with the plans and specifications approved by the MPCA. [Minn. R. 7001.0150, subp. 3(E)]
5.14.168	Toxic Discharges Prohibited. Whether or not this permit includes effluent limitations for toxic pollutants, the Permittee shall not discharge a toxic pollutant except according to 40 CFR pts. 400 to 460 and Minn. R. chs. 7050, 7052, 7053 and any other applicable MPCA rules. [Minn. R. 7001.1090, subp. 1(A)]
5.14.169	Nuisance Conditions Prohibited. The Permittee's discharge shall not cause any nuisance conditions including, but not limited to: floating solids, scum and visible oil film, excessive suspended solids, material discoloration, obnoxious odors, gas ebullition, deleterious sludge deposits, undesirable slimes or fungus growths, aquatic habitat degradation, excessive growths of aquatic plants, acutely toxic conditions to aquatic life, or other adverse impact on the receiving water. [Minn. R. 7050.0210, subp. 2]
5.14.170	Property Rights. This permit does not convey a property right or an exclusive privilege. [Minn. R. 7001.0150, subp. 3(C)]

5.14.171	Liability Exemption. In issuing this permit, the State and the MPCA assume no responsibility for damage to persons, property, or the environment caused by the activities of the Permittee in the conduct of its actions, including those activities authorized, directed, or undertaken under this permit. To the extent the State and the MPCA may be liable for the activities of its employees, that liability is explicitly limited to that provided in the Tort Claims Act. [Minn. R. 7001.0150, subp. 3(O)]
5.14.172	The MPCA's issuance of this permit does not obligate the MPCA to enforce local laws, rules, or plans beyond what Minnesota statutes authorize. [Minn. R. 7001.0150, subp. 3(D)]
5.14.173	Liabilities. The MPCA's issuance of this permit does not release the Permittee from any liability, penalty, or duty imposed by Minnesota or federal statutes or rules or local ordinances, except the obligation to obtain the permit. [Minn. R. 7001.0150, subp. 3(A)]
5.14.174	The issuance of this permit does not prevent the future adoption by the MPCA of pollution control rules, standards, or orders more stringent than those now in existence and does not prevent the enforcement of these rules, standards, or orders against the Permittee. [Minn. R. 7001.0150, subp. 3(B)]
5.14.175	Severability. The provisions of this permit are severable and, if any provisions of this permit or the application of any provision of this permit to any circumstance are held invalid, the application of such provision to other circumstances and the remainder of this permit shall not be affected thereby. [Minn. R. 7001]
5.14.176	Compliance with Other Rules and Statutes. The Permittee shall comply with all applicable air quality, solid waste, and hazardous waste statutes and rules in the operation and maintenance of the facility. [Minn. R. 7001]
5.14.177	Inspection and Entry. When authorized by Minn. Stat. ch. 115.04, 115B.17, subd. 4, and 116.091, and upon presentation of proper credentials, the Permittee shall allow the MPCA, or an authorized employee or agent of the MPCA, to enter at reasonable times upon the property of the Permittee to examine and copy books, papers, records, or memoranda pertaining to the construction, modification, or operation of the facility covered by the permit or pertaining to the activity covered by the permit; and to conduct surveys and investigations, including sampling or monitoring, pertaining to the construction, modification, or operation of the facility covered by the permit or pertaining to the activity covered by the permit. [Minn. R. 7001.0150, subp. 3(I)]
5.14.178	Control Users. The Permittee shall regulate the users of its facility to prevent the introduction of pollutants or materials that may result in the inhibition or disruption of the conveyance system, treatment facility or processes, or disposal system that would contribute to the violation of the conditions of this permit or any federal, state, or local law or regulation. [Minn. R. 7001.0150, subp. 3(F)]
5.14.179	Sampling. [Minn. R. 7001]
5.14.180	Representative Sampling. The Permittee shall conduct samples and measurements required by this permit as specified in this permit and shall be representative of the discharge or monitored activity. [Minn. R. 7001.0150, subp. 2(B)]
5.14.181	Additional Sampling. If the Permittee monitors more frequently than required, they shall report the results and the frequency of monitoring on their eDMR for that reporting period. [Minn. R. 7001.1090, subp. 1(E)]
5.14.182	Certified/Accredited Laboratory. A laboratory accredited by the Minnesota Department of Health [Minn. R. 4740.2010 through Minn. R. 4740.2120] and/or certified by the MPCA [Minn. R. 7001.4310 through Minn. R. 7001.4390] shall conduct analyses required by this permit, unless approved in writing by the MPCA. A certified/accredited laboratory does not need to complete analyses of dissolved oxygen, pH, temperature, specific conductance, and total residual oxidants (chlorine, bromine). Those analyses shall comply with 40 CFR pt. 136. Dissolved oxygen, pH, and total residual oxidants must be performed on-site. Follow the manufacturer's specifications for equipment maintenance and use. [Minn. R. 4740.2010-4740.2120, Minn. R. 7001.4310-7001.4390]
5.14.183	Sample Preservation and Procedure. Sample preservation and test procedures for the analysis of pollutants shall conform to 40 CFR pt. 136 and Minn. R. 7041.3200. [Minn. R. 7001.0150, subp. 2(B), Minn. R. 7041.3200]

5.14.184	Equipment Calibration. The Permittee shall check and/or calibrate flow meters, pumps, flumes, lift stations, or other flow monitoring equipment used for purposes of determining compliance (within plus or minus ten percent of the true flow values) with permit requirements at least twice annually. [Minn. R. 7001.0150, subp. 2(B & C)]
5.14.185	Maintain Records. The Permittee shall keep the records required by this permit for at least three years, including any calculations, original recordings from automatic monitoring instruments, and laboratory sheets. The Permittee shall extend these record retention periods upon request of the MPCA. The Permittee shall maintain records for each sample and measurement. The records shall include the following information: A. The exact place, date, and time of the sample or measurement; B. The date and time of analysis; C. The name of the person who performed the sample collection, measurement, analysis, or calculation; D. The analytical techniques, procedures, and methods used; and E. The results of the analysis. [Minn. R. 7001.0150, subp. 2(C)]
5.14.186	Completing Reports. The Permittee shall submit the results of the required sampling and monitoring activities on the forms provided, specified, or approved by the MPCA. The Permittee shall record the information in the specified areas on those forms and in the units specified. Required forms may include a Sample Values Form. If required, the Permittee shall record individual values for each sample and measurement on the Sample Values Form provided by the MPCA. The Permittee shall submit Sample Values Form with the appropriate eDMRs. The Permittee may design and use their own Sample Values Form; however, the Permittee shall not use their form until the MPCA reviews and approves the form. Note: The Permittee shall also record required summary information on their eDMR. Permittee submitted summary information contained only on the Sample Values Form does not comply with reporting requirements. [Minn. R. 7001.0150, subp. 2(B), Minn. R. 7001.1090, subp. 1(D)]
5.14.187	Submitting Reports. The Permittee shall submit eDMRs, Sample Values Forms, and other supplemental attachment forms via MPCA e-Services after the MPCA approves their authorization request. The Permittee shall electronically submit eDMRs, Sample Values Forms, and other supplemental attachment forms by the 21st day of the month following the sampling period or otherwise as specified in this permit. The Permittee shall complete eDMR submittal on or before 11:59 p.m. of the 21st day of the month following the sampling period or as otherwise specified in this permit. The Permittee shall submit an eDMR for each required station even if no discharge occurred during the reporting period. The Permittee shall submit other reports required by this permit electronically. The Permittee shall submit reports by the date specified in this permit. The Permittee shall submit on or before 11:59 p.m. on the date specified in this permit. Electronically: wq.submittals.mPCA@state.mn.us Include Water quality submittals form: www.pca.state.mn.us/sites/default/files/wq-wwprm7-71.docx . [Minn. R. 7001.0150, subp. 2(B), Minn. R. 7001.0150, subp. 3(H)]
5.14.188	Incomplete or Incorrect Reports. The Permittee shall immediately submit an electronically amended report or eDMR to the MPCA upon discovery by the Permittee or notification by the MPCA that it has submitted an incomplete or incorrect report or eDMR. The amended report or eDMR shall contain the missing or corrected data along with a comment on the eDMR explaining the circumstances of the incomplete or incorrect report. If it is impossible to amend the report or eDMR electronically, the Permittee shall immediately notify the MPCA and the MPCA will provide direction for the amendment submittals. [Minn. R. 7001.0150, subp. 3(G)]

5.14.189	<p>Required Signatures. The Permittee or the duly authorized representative of the Permittee shall sign all eDMRs, forms, reports, and other documents submitted to the MPCA per Minn. R. 7001.0150, subp. 2(D). The person or persons who sign the eDMRs, forms, reports, or other documents shall certify that he or she understands and complies with the certification requirements of Minn. R. chs. 7001.0070 and 7001.0540, including the penalties for submitting false information. A registered professional engineer shall certify technical documents, such as design drawings and specifications, and engineering studies submitted as part of a permit application or by permit conditions. [Minn. R. 7001.0540]</p>
5.14.190	<p>Reporting Limit (RL). The Permittee shall report monitoring results below the RL of a particular instrument as "<" the value of the RL. For example, if an instrument has a RL of 0.1 mg/L and a parameter is not detected at a value of 0.1 mg/L or greater, the Permittee shall report the concentration as "< 0.1 mg/L." The Permittee shall not use "non-detected," "undetected," "below detection limit," or "zero" when reporting results. The MPCA considers these terms as permit reporting violations.</p> <p>Where sample values are less than the RL and the permit requires reporting of an average, the Permittee shall calculate the average as follows:</p> <p>A. If some values are less than (<) the RL, substitute zero for all non-detectable values to use in the average calculation;</p> <p>B. If all values are less than (<) the RL, calculate the average and report as < the RL average concentration; and</p> <p>C. To calculate a mass loading with a less than (<) the RL concentration, use the RL value in the calculation and then add the "<" to the product of the concentration and the volume. [Minn. R. 7001.0150, subp. 2(B)]</p>
5.14.191	<p>Records. The Permittee shall, when requested by the MPCA, submit within a reasonable time the information and reports that are relevant to the control of pollution regarding the construction, modification, or operation of the facility covered by the permit or regarding the conduct of the activity covered by the permit. [Minn. R. 7001.0150, subp. 3(H)]</p>
5.14.192	<p>Confidential Information. Except for data determined to be confidential according to Minn. Stat. ch. 116.075, subd. 2, all reports required by this permit are available for public inspection. The MPCA does not consider effluent data confidential. To request the MPCA maintain data as confidential, the Permittee shall follow Minn. R. 7000.1300. [Minn. R. 7000.1300]</p>
5.14.193	<p>Noncompliance and Enforcement. [Minn. R. 7001]</p>
5.14.194	<p>Subject to Enforcement Action and Penalties. Noncompliance with a term or condition of this permit subjects the Permittee to penalties provided by federal and state law set forth in section 309 of the Clean Water Act; United States Code, title 33, section 1319, as amended; and in Minn. Stat. ch. 115.071 and 116.072, including monetary penalties, imprisonment, or both. [Minn. R. 7001.1090, subp. 1(B)]</p>
5.14.195	<p>Criminal Activity. The Permittee shall not knowingly make a false statement, representation, or certification in a record or other document submitted to the MPCA. A person who falsifies a report or document submitted to the MPCA, or tampers with, or knowingly renders inaccurate a monitoring device or method that requires maintenance under this permit is subject to criminal and civil penalties provided by federal and state law. [Minn. R. 7001.0150, subp. 3(G), Minn. R. 7001.1090, subp. 1(G & H), Minn. Stat. ch. 609.671, subd. 1]</p>
5.14.196	<p>Noncompliance Defense. It shall not be a defense for the Permittee in an enforcement action that it would have been necessary to halt or reduce the permitted activity in order to maintain compliance with the conditions of this permit. [40 CFR 122.41(c)]</p>

5.14.197	<p>Effluent Violations. If sampling by the Permittee indicates a violation of any discharge limitation specified in this permit, the Permittee shall immediately make every effort to verify the violation by collecting additional samples, if appropriate, investigate the cause of the violation, and take action to prevent future violations.</p> <p>If the Permittee discovers that noncompliance with a condition of the permit occurred and that the noncompliance could endanger human health, public drinking water supplies, or the environment, the Permittee shall within 24 hours of the discovery of the noncompliance orally notify the Commissioner and submit a written description of the noncompliance within five days of the discovery.</p> <p>If the Permittee discovers other noncompliance that does not explicitly endanger human health, public drinking water supplies, or the environment, the Permittee shall report the description of noncompliance within 30 days of the discovery. If no eDMR is required within 30 days, the Permittee shall submit a written report including the description of noncompliance within 30 days of the discovery of the noncompliance. This description shall include the following information:</p> <ul style="list-style-type: none">A. A description of the event including volume, duration, monitoring results, and receiving waters;B. The cause of the event;C. The steps taken to reduce, eliminate, and prevent reoccurrence of the event;D. The exact dates and times of the event; andE. Steps taken to reduce any adverse impact resulting from the event. [Minn. R. 7001.0150, subp. 3(K)]
5.14.198	<p>Upset Defense. In the event of temporary noncompliance with applicable effluent limitation(s) resulting from an upset at the Permittee's facility due to factors beyond the control of the Permittee, the Permittee has an affirmative defense to an enforcement action brought by the MPCA as a result of the noncompliance if the Permittee demonstrates by a preponderance of competent evidence:</p> <ul style="list-style-type: none">A. The specific cause of the upset;B. That the upset was unintentional;C. That the upset resulted from factors beyond the reasonable control of the Permittee and did not result from operational error, improperly designed treatment facilities, inadequate treatment facilities, lack of preventative maintenance, or increases in production which are beyond the design capability of the treatment facilities;D. That at the time of the upset the facility was being properly operated;E. That the Permittee properly notified the Commissioner of the upset in accordance with Minn. R. 7001.1090, subp. 1(I); andF. That the Permittee implemented the remedial measures required by Minn. R. 7001.0150, subp. 3(J). <p>[Minn. R. 7001.1090]</p>
5.14.199	<p>Release. [Minn. R. 7001]</p>
5.14.200	<p>Unauthorized Releases of Wastewater Prohibited. This permit prohibits overflows, discharges, spills, or other releases of wastewater or materials to the environment, whether intentional or not, except for discharges from outfalls specifically authorized by this permit. The MPCA will consider the Permittee's compliance with permit requirements, frequency of release, quantity, type, location, and other relevant factors when determining appropriate action. [40 CFR 122.41, Minn. Stat. ch. 115.061]</p>
5.14.201	<p>Discovery of a Release. Upon discovery of a release, the Permittee shall:</p> <ul style="list-style-type: none">A. Take all reasonable steps to immediately end the release;B. Notify the Minnesota Department of Public Safety Duty Officer at 800-422-0798 or 651-649-5451 (metro area) immediately upon discovery of the release. The Permittee may contact the MPCA during business hours at 800-657-3864 or 651-296-6300 (metro area); andC. Recover as rapidly and as thoroughly as possible all substances and materials released or immediately take other action as may be reasonably possible to minimize or abate pollution to waters of the state or potential impacts to human health caused thereby. If the Permittee cannot immediately or completely recover the released materials or substances, the Permittee shall contact the MPCA. If directed by the MPCA, the Permittee shall consult with other local, state, or federal agencies (such as the Minnesota Department of Natural Resources and/or the Wetland Conservation Act authority) for implementation of additional clean up or remediation activities in wetland or other sensitive areas. [Minn. R. 7001.1090]

5.14.202	<p>Sampling of a Release. Upon discovery of a release, the Permittee shall:</p> <p>A. Collect representative samples of the release. The Permittee shall sample the release for permitted effluent parameters and other parameters of concern immediately following discovery of the release. The Permittee may contact the MPCA during business hours to discuss the sampling parameters and protocol. In addition, the Permittee shall collect fecal coliform bacteria samples where the Permittee determines that the release contains or may contain sewage. If the Permittee cannot immediately stop the release, the Permittee shall consult with the MPCA regarding additional sampling requirements. The Permittee shall collect samples at least, but not limited to, two times per week for as long as the release continues; and</p> <p>B. Submit the sampling results on the Release Report located on the MPCA's website at https://www.pca.state.mn.us/business-with-us/discharge-monitoring-reports.</p> <p>The Permittee shall submit the Release Report to the MPCA with the next eDMR or within 30 days, whichever is sooner. [Minn. R. 7001.1090]</p>
5.14.203	<p>Bypass. [Minn. R. 7001]</p>
5.14.204	<p>Anticipated Bypass. The Permittee may allow any bypass to occur that does not cause effluent limitation exceedances, but only if the bypass is for essential maintenance to assure efficient operation of the facility. The Permittee shall submit prior notice to the MPCA at least ten days before the date of the bypass, if possible. The notice of the need for an anticipated bypass shall include the following information:</p> <p>A. The proposed date and estimated duration of the bypass;</p> <p>B. The alternatives to bypassing; and</p> <p>C. A proposal for effluent sampling during the bypass. Any bypass wastewater shall enter waters of the state from outfalls specifically authorized by this permit. Therefore, the Permittee shall collect samples at the frequency and location identified in this permit or two times per week for as long as the bypass continues, whichever is more frequent. [40 CFR 122.41(m)(2 & 3), Minn. R. 7001.1090, subp. 1(J)]</p>
5.14.205	<p>This permit prohibits all other bypasses. The MPCA may take enforcement action against the Permittee for a bypass, unless the specific conditions described in Minn. R. 7001.1090 subp. 1(K) and 40 CFR 122.41(m)(4)(i) are met.</p> <p>In the event of an unanticipated bypass, the Permittee shall:</p> <p>A. Take all reasonable steps to immediately end the bypass;</p> <p>B. Notify the Minnesota Department of Public Safety Duty Officer at 800-422-0798 or 651-649-5451 (metro area) immediately upon commencement of the bypass. The Permittee may contact the MPCA during business hours at 800-657-3864 or 651-296-6300 (metro area);</p> <p>C. Immediately take action as may be reasonably possible to minimize or abate pollution to waters of the state or potential impacts to human health caused thereby. If directed by the MPCA, the Permittee shall consult with other local, state, or federal agencies for implementation of abatement, clean up, or remediation activities; and</p> <p>D. Only allow bypass wastewater as specified in this section to enter waters of the state from outfalls specifically authorized by this permit. The Permittee shall collect samples at the frequency and location identified in this permit or two times per week for as long as the bypass continues, whichever is more frequent. The Permittee shall also follow the reporting requirements for effluent violations as specified in this permit. [40 CFR 122.41(m)(4)i, Minn. R. 7001.1090, subp. 1(K), Minn. Stat. ch. 115.061]</p>

5.14.206	<p>Notification of the Public. Following immediate notification to the Minnesota Department of Public Safety Duty Officer and the MPCA of any discharge event that could endanger human health, public drinking water supplies, or the environment, or a Release or Bypass, as described above, the Permittee shall promptly notify the public and any drinking water facility of the discharge.</p> <p>Notice to the public and to any drinking water facility must be made using the most efficient communications system available to the facility owner such as in person, telephone call, radio, social media, webpage, or another expedited form. In addition, signage must be posted at all impacted public use areas within the same jurisdiction or notification must be provided to the entity that has jurisdiction over any impacted public use areas. A notice under this requirement must include the date and time of the discharge, a description of the material released, a warning of the potential public health risk, and the Permittee's contact information. [Minn. Stat. ch. 115.061]</p>
5.14.207	<p>Operation and Maintenance. [Minn. R. 7001]</p>
5.14.208	<p>The Permittee shall at all times properly operate and maintain the facilities and systems of treatment and control, and the appurtenances related to them which are installed or used by the Permittee to achieve compliance with the conditions of the permit. Proper operation and maintenance includes effective performance, adequate funding, adequate operator staffing and training, and adequate laboratory and process controls, including appropriate quality assurance procedures. The Permittee shall install and maintain appropriate backup or auxiliary facilities if they are necessary to achieve compliance with the conditions of the permit and, for all permits other than hazardous waste facility permits, if these backup or auxiliary facilities are technically and economically feasible. [Minn. R. 7001.0150, subp. 3(F)]</p>
5.14.209	<p>In the event of a reduction or loss of effective treatment of wastewater at the facility, the Permittee shall control production or curtail discharges to the extent necessary to maintain compliance with the terms and conditions of this permit. The Permittee shall continue this control or curtailment until they restore facility treatment processes or until the Permittee provides an alternative method of treatment. [Minn. R. 7001.1090, subp. 1(C)]</p>
5.14.210	<p>Solids Management. The Permittee shall properly store, transport, and manage biosolids, septage, sediments, residual solids, filter backwash, screenings, oil, grease, and other substances so that pollutants do not enter surface waters or groundwaters of the state. The Permittee shall manage solids in accordance with local, state, and federal requirements. [40 CFR 503, Minn. R. 7041]</p>
5.14.211	<p>Scheduled Maintenance. The Permittee shall schedule maintenance of the treatment works during non-critical water quality periods to prevent water quality degradation, except where the facility requires emergency maintenance to prevent a condition that would be detrimental to water quality or human health. [Minn. R. 7001.0150, subp. 2(B), Minn. R. 7001.0150, subp. 3(F)]</p>
5.14.212	<p>Control Tests. The Permittee shall conduct in-plant control tests at a frequency adequate to ensure compliance with the conditions of this permit. [Minn. R. 7001.0150, subp. 2(B), Minn. R. 7001.0150, subp. 3(F)]</p>
5.14.213	<p>Changes to the Facility or Permit. [Minn. R. 7001]</p>
5.14.214	<p>Permit Modifications. Except as provided under Minn. Stat. ch. 115.07, subd. 1 and 3, no person required by statute or rule to obtain a permit may construct, install, modify, or operate the facility to be permitted, nor shall a person commence an activity for which a permit is required by statute or rule until the MPCA issues a written permit for the facility or activity.</p> <p>Permittees that propose to make changes to the facility or discharge that requires permit modification shall follow Minn. R. 7001.0190. If the Permittee cannot determine whether the proposed changes require a permit modification, the Permittee shall contact the MPCA prior to any action. The MPCA recommends that Permittees submit the application for permit modification to the MPCA at least 180 days prior to the planned change. [Minn. R. 7001.0030]</p>

5.14.215	<p>This permit does not require plans, specifications, and MPCA approval when maintenance dictates the need for installation of new equipment, provided the equipment is the same design size and has the same design intent. For instance, Permittees can replace a broken pipe, lift station pump, aerator, or blower with the same design-sized equipment without MPCA approval.</p> <p>If this permit does not expressly authorize the Permittee proposed construction, the MPCA may require a permit modification. If the proposed construction project requires an Environmental Assessment Worksheet under Minn. R. 4410, no construction shall begin until the MPCA issues a negative declaration and the Permittee receives or implements all approvals. [Minn. R. 7001.0030]</p>
5.14.216	<p>Report Changes. The Permittee shall give advance notice as soon as possible to the MPCA of any substantial changes in operational procedures, activities that may alter the nature or frequency of the discharge, and/or material factors that may affect compliance with the conditions of this permit. [Minn. R. 7001.0150, subp. 3(M)]</p>
5.14.217	<p>Chemical Additives. The Permittee shall receive prior written approval from the MPCA before increasing the use of a chemical additive authorized by this permit, or using a chemical additive not authorized by this permit, in quantities or concentrations that have the potential to change the characteristics, nature, and/or quality of the discharge.</p> <p>The Permittee shall request approval for an increase or new use of a chemical additive at least 60 days, or as soon as possible, before the proposed increase or new use. The Permittee shall include at least the following information for the proposed additive as instructed in the chemical additive approvals section on the MPCA's website at https://www.pca.state.mn.us/business-with-us/wastewater-permit-additional-guidance-and-information:</p> <ul style="list-style-type: none"> A. The process for which the additive will be used; B. Safety Data Sheet (SDS) which shall include aquatic toxicity, human health, and environmental fate information for the proposed additive. The aquatic toxicity information shall include at minimum the results of: a) a 48-hour LC50 or EC50 acute study for a North American freshwater planktonic crustacean (either Ceriodaphnia or Daphnia sp.) and b) a 96-hour LC50 acute study for rainbow trout, bluegill, or fathead minnow or another North American freshwater aquatic species other than a planktonic crustacean; C. A complete product use and instruction label; D. The commercial and chemical names and Chemical Abstract Survey (CAS) number for all ingredients in the additive (If the SDS does not include information on chemical composition, including percentages for each ingredient totaling to 100%, the Permittee shall contact the supplier to have this information provided); and E. The proposed method of application, application frequency, concentration, and daily average and maximum rates of use. <p>Upon review of the information submitted regarding the proposed chemical additive, the MPCA may require additional information be submitted for consideration. This permit may be modified to restrict the use or discharge of a chemical additive and include additional influent and effluent monitoring requirements. Approval for the use of an additive shall not justify the exceedance of any effluent limitation nor shall it be used as a defense against pollutant levels in the discharge causing or contributing to the violation of a water quality standard. [Minn. R. 7001.0170]</p>
5.14.218	<p>MPCA Initiated Permit Modification, Suspension, or Revocation. The MPCA may modify or revoke and reissue this permit pursuant to Minn. R. 7001.0170. The MPCA may revoke without reissuance of this permit pursuant to Minn. R. 7001.0180. [Minn. R. 7001.0170, Minn. R. 7001.0180]</p>
5.14.219	<p>Total Maximum Daily Load (TMDL) Impacts. The MPCA may require facilities that discharge to an impaired surface water, watershed, or drainage basin to comply with additional permits or permit requirements. These requirements can include additional restriction or relaxation of limits and monitoring as authorized by the CWA 303(d)(4)(A) and 40 CFR ch. 122.44(l)(2)(i), necessary to ensure consistency with the assumptions and requirements of any applicable EPA approved wasteload allocations resulting from TMDL studies. [40 CFR 122.44(l)(2)(i)]</p>

5.14.220	Permit Transfer. This permit is not transferable to any person without the express written approval of the MPCA after compliance with the requirements of Minn. R. 7001.0190. A person who receives permit transference shall comply with the conditions of this permit. [Minn. R. 7001.0150, subp. 3(N)]
5.14.221	Facility Closure. The Permittee is responsible for closure and post-closure care of the facility. The Permittee shall notify the MPCA of a significant reduction or cessation of the activities described in this permit at least 180 days before the reduction or cessation. The MPCA may require the Permittee to provide a Facility Closure Plan to the MPCA for approval. The MPCA may require a permit modification or reissuance for facility closure that could result in a potential long-term water quality concern, such as the ongoing discharge of wastewater to surface or groundwater. The MPCA may require the Permittee to establish and maintain financial assurance to ensure performance of certain obligations under this permit, including closure, post-closure care, and remedial action at the facility. If the MPCA requires financial assurance, the MPCA shall approve the amount and type of financial assurance, and proposed modifications to previously MPCA-approved financial assurance. [Minn. Stat. ch. 116.07, subd. 4]
5.14.222	Permit Reissuance. If the Permittee desires to continue permit coverage beyond the date of permit expiration, the Permittee shall submit an application for permit reissuance : Due by 180 days prior to permit expiration. [Minn. R. 7001.0040]
5.14.223	If the Permittee does not intend to continue the activities authorized by this permit after the expiration date of this permit, the Permittee shall notify the MPCA in writing at least 180 days before permit expiration. If the Permittee has submitted a timely application for permit reissuance, the Permittee may continue to conduct the activities authorized by this permit, in compliance with the requirements of this permit, until the MPCA takes final action on the application, unless the MPCA determines any of the following: A. The Permittee is not in substantial compliance with the requirements of this permit, or with a stipulation agreement or compliance schedule designed to bring the Permittee into compliance with this permit; B. The MPCA, as a result of an action or failure to act by the Permittee, has been unable to take final action on the application on or before the expiration date of the permit; or C. The Permittee has submitted an application with major deficiencies or has failed to properly supplement the application in a timely manner after being informed of deficiencies. [Minn. R. 7001.0040, Minn. R. 7001.0160]

6. Submittal action summary

SD 001	Effluent To Surface Water	
		Surface Discharge: Class A Major Facility Effluent Requirements
	6.1.1	The Permittee shall submit a monthly DMR : Due by 21 days after the end of each calendar month following permit issuance. [Minn. R. 7001.0150, subp. 2(B)]
		Priority Pollutant Requirements
	6.2.2	The Permittee shall submit the first priority pollutant monitoring report : Due 1095 calendar days before Permit Expiration Date. (By two years after permit issuance date). [Minn. R. 7001]
	6.2.3	The Permittee shall submit the second priority pollutant monitoring report : Due 730 calendar days before Permit Expiration Date. (By three years after permit issuance date). [Minn. R. 7001]
	6.2.4	The Permittee shall submit the third priority pollutant monitoring report : Due 365 calendar days before Permit Expiration Date. (By four years after permit issuance date). [Minn. R. 7001]
		Chronic Toxicity Requirements
	6.3.5	The Permittee shall submit annual chronic toxicity test battery results : Due 180 calendar days after Permit Issuance Date annually thereafter. [Minn. R. 7001]
WS 001	Influent Waste	
		Waste Stream: Class A Major Facility Influent Requirements
	6.4.1	The Permittee shall submit a monthly DMR : Due by 21 days after the end of each calendar month following permit issuance. [Minn. R. 7001.0150, subp. 2(B)]
MN0064190	Otsego East WWTF	
		Nitrogen Management Plan - Enhanced
	6.5.1	The Permittee shall submit a nitrogen management plan : Due by 18 months after permit issuance. [Minn. R. 7001]
		Biosolids: Exceptional Quality
	6.6.2	The Permittee shall submit a biosolids annual report : Due annually, by the 31st of December. [Minn. R. 7041]
		Total Facility Requirements (NPDES/SDS)
	6.7.3	Permit Reissuance. If the Permittee desires to continue permit coverage beyond the date of permit expiration, the Permittee shall submit an application for permit reissuance : Due by 180 days prior to permit expiration. [Minn. R. 7001.0040]

7. Limits and monitoring

The Permittee shall comply with the limits and monitoring requirements as specified below.

Subject item	Parameter	Discharge limitations							Monitoring requirements			Notes
		Quantity /Loading avg.	Quantity /Loading max.	Quantity /Loading units	Quality /Conc. min.	Quality /Conc. avg.	Quality /Conc. max.	Quality/ Conc. units	Frequency	Sample type	Effective period	
SD 001 Surface Water Discharge Phase 1	BOD, Carbonaceous 05 Day (20 Deg C)	104 calendar month average	166 maximum calendar week average	kilograms per day		25 calendar month average	40 maximum calendar week average	milligrams per liter	3 times per week	24-Hour Flow Composite	Apr-Nov	
SD 001 Surface Water Discharge Phase 1	BOD, Carbonaceous 05 Day (20 Deg C)	62 calendar month average	104 maximum calendar week average	kilograms per day		15 calendar month average	25 maximum calendar week average	milligrams per liter	3 times per week	24-Hour Flow Composite	Dec-Mar	
SD 001 Surface Water Discharge Phase 2	BOD, Carbonaceous 05 Day (20 Deg C)	156 calendar month average	250 maximum calendar week average	kilograms per day		25 calendar month average	40 maximum calendar week average	milligrams per liter	3 times per week	24-Hour Flow Composite	Apr-Nov	
SD 001 Surface Water Discharge Phase 2	BOD, Carbonaceous 05 Day (20 Deg C)	93 calendar month average	156 maximum calendar week average	kilograms per day		15 calendar month average	25 maximum calendar week average	milligrams per liter	3 times per week	24-Hour Flow Composite	Dec-Mar	
SD 001 Surface Water Discharge	BOD, Carbonaceous 05 Day (20 Deg C) Percent Removal				85 minimum calendar month average			percent	once per month	Calculation	Jan-Dec	
SD 001 Surface Water Discharge	Fecal Coliform, MPN or Membrane Filter 44.5C					200 calendar month geometric mean		organisms per 100 milliliter	3 times per week	Grab	Jan-Dec	
SD 001 Surface Water Discharge	Flow		Monitor only. calendar month total	million gallons		Monitor only. calendar month average	Monitor only. calendar month maximum	million gallons per day	once per day	Measurement, Continuous	Jan-Dec	
SD 001 Surface Water Discharge	Mercury, Dissolved (as Hg)						Monitor only. calendar month maximum	nanograms per liter	twice per month	Grab	Jan, Mar, May, Jul, Sep, Nov	
SD 001 Surface Water Discharge	Mercury, Total (as Hg)					10.0 calendar month average	17.0 daily maximum	nanograms per liter	twice per month	Grab	Jan, Mar, May, Jul, Sep, Nov	

Subject item	Parameter	Discharge limitations							Monitoring requirements			Notes
		Quantity /Loading avg.	Quantity /Loading max.	Quantity /Loading units	Quality /Conc. min.	Quality /Conc. avg.	Quality /Conc. max.	Quality/ Conc. units	Frequency	Sample type	Effective period	
SD 001 Surface Water Discharge	Nitrite Plus Nitrate, Total (as N)					Monitor only. calendar month average		milligrams per liter	once per month	24-Hour Flow Composite	Jan-Dec	
SD 001 Surface Water Discharge Phase 1	Nitrogen, Ammonia, Total (as N)	41 calendar month average		kilograms per day		9.9 calendar month average		milligrams per liter	3 times per week	24-Hour Flow Composite	Jun-Sep	
SD 001 Surface Water Discharge Phase 1	Nitrogen, Ammonia, Total (as N)	21 calendar month average		kilograms per day		5 calendar month average		milligrams per liter	3 times per week	24-Hour Flow Composite	Dec-Mar	
SD 001 Surface Water Discharge Phase 1	Nitrogen, Ammonia, Total (as N)	58 calendar month average		kilograms per day		14 calendar month average		milligrams per liter	3 times per week	24-Hour Flow Composite	Oct-Nov	
SD 001 Surface Water Discharge Phase 2	Nitrogen, Ammonia, Total (as N)	31 calendar month average		kilograms per day		5 calendar month average		milligrams per liter	3 times per week	24-Hour Flow Composite	Dec-Mar	
SD 001 Surface Water Discharge Phase 2	Nitrogen, Ammonia, Total (as N)	62 calendar month average		kilograms per day		9.9 calendar month average		milligrams per liter	3 times per week	24-Hour Flow Composite	Jun-Sep	
SD 001 Surface Water Discharge Phase 2	Nitrogen, Ammonia, Total (as N)	87 calendar month average		kilograms per day		14 calendar month average		milligrams per liter	3 times per week	24-Hour Flow Composite	Oct-Nov	
SD 001 Surface Water Discharge	Nitrogen, Ammonia, Total (as N)	Monitor only. calendar month average		kilograms per day		Monitor only. calendar month average		milligrams per liter	3 times per week	24-Hour Flow Composite	Apr-May	
SD 001 Surface Water Discharge	Nitrogen, Kjeldahl, Total					Monitor only. calendar month average		milligrams per liter	once per month	24-Hour Flow Composite	Jan-Dec	
SD 001 Surface Water Discharge	Nitrogen, Total (as N)					Monitor only. calendar month average		milligrams per liter	once per month	Calculation	Jan-Dec	

Subject item	Parameter	Discharge limitations							Monitoring requirements			Notes
		Quantity /Loading avg.	Quantity /Loading max.	Quantity /Loading units	Quality /Conc. min.	Quality /Conc. avg.	Quality /Conc. max.	Quality/ Conc. units	Frequency	Sample type	Effective period	
SD 001 Surface Water Discharge	Oxygen, Dissolved				6.0 calendar month minimum			milligrams per liter	once per day	Grab	Dec-Mar	
SD 001 Surface Water Discharge	Oxygen, Dissolved				Monitor only. calendar month minimum			milligrams per liter	once per day	Grab	Apr-Nov	
SD 001 Surface Water Discharge	pH				6.0 calendar month minimum		9.0 calendar month maximum	standard units	once per day	Grab	Jan-Dec	
SD 001 Surface Water Discharge	Phosphorus, Total (as P)	Monitor only. calendar month average		kilograms per day		Monitor only. calendar month average		milligrams per liter	3 times per week	24-Hour Flow Composite	Oct-May	
SD 001 Surface Water Discharge	Phosphorus, Total (as P)		2114 12-month moving total	kilograms per year		1.0 12-month moving average		milligrams per liter	once per month	Calculation	Jan-Dec	
SD 001 Surface Water Discharge	Phosphorus, Total (as P)	3.5 calendar month average		kilograms per day		Monitor only. calendar month average		milligrams per liter	once per week	24-Hour Flow Composite	Jun-Sep	
SD 001 Surface Water Discharge	Solids, Total Dissolved (TDS)					Monitor only. calendar month average		milligrams per liter	once per month	24-Hour Flow Composite	Mar, Sep	
SD 001 Surface Water Discharge Phase 1	Solids, Total Suspended (TSS)	125 calendar month average	187 maximum calendar week average	kilograms per day		30 calendar month average	45 maximum calendar week average	milligrams per liter	3 times per week	24-Hour Flow Composite	Jan-Dec	
SD 001 Surface Water Discharge Phase 2	Solids, Total Suspended (TSS)	187 calendar month average	281 maximum calendar week average	kilograms per day		30 calendar month average	45 maximum calendar week average	milligrams per liter	3 times per week	24-Hour Flow Composite	Jan-Dec	
SD 001 Surface Water Discharge	Solids, Total Suspended (TSS) Percent Removal				85 minimum calendar month average			percent	once per month	Calculation	Jan-Dec	
SD 001 Surface Water Discharge	Solids, Total Suspended (TSS), grab (Mercury)						Monitor only. calendar month maximum	milligrams per liter	twice per month	Grab	Jan, Mar, May, Jul, Sep, Nov	

Subject item	Parameter	Discharge limitations							Monitoring requirements			Notes	
		Quantity /Loading avg.	Quantity /Loading max.	Quantity /Loading units	Quality /Conc. min.	Quality /Conc. avg.	Quality /Conc. max.	Quality/ Conc. units	Frequency	Sample type	Effective period		
SD 001 Surface Water Discharge	Sulfate, Total (as SO4)							Monitor only. calendar month maximum	milligrams per liter	once per quarter	24-Hour Flow Composite	Mar, Jun, Sep, Dec	
WS 001 Influent Waste Stream	BOD, Carbonaceous 05 Day (20 Deg C)							Monitor only. calendar month average	milligrams per liter	3 times per week	24-Hour Flow Composite	Jan-Dec	
WS 001 Influent Waste Stream	Flow		Monitor only. calendar month total	million gallons				Monitor only. calendar month average	million gallons per day	once per day	Measurement, Continuous	Jan-Dec	
WS 001 Influent Waste Stream	Mercury, Total (as Hg)							Monitor only. calendar month maximum	milligrams per liter	twice per month	Grab	Jan, Mar, May, Jul, Sep, Nov	
WS 001 Influent Waste Stream	Nitrite Plus Nitrate, Total (as N)							Monitor only. calendar month average	milligrams per liter	once per month	24-Hour Flow Composite	Jan-Dec	
WS 001 Influent Waste Stream	Nitrogen, Kjeldahl, Total							Monitor only. calendar month average	milligrams per liter	once per month	24-Hour Flow Composite	Jan-Dec	
WS 001 Influent Waste Stream	Nitrogen, Total (as N)							Monitor only. calendar month average	milligrams per liter	once per month	Calculation	Jan-Dec	
WS 001 Influent Waste Stream	pH				Monitor only. calendar month minimum			Monitor only. calendar month maximum	standard units	once per day	Grab	Jan-Dec	
WS 001 Influent Waste Stream	Phosphorus, Total (as P)							Monitor only. calendar month average	milligrams per liter	once per week	24-Hour Flow Composite	Jan-Dec	
WS 001 Influent Waste Stream	Precipitation		Monitor only. calendar month total	inches						once per day	Measurement	Jan-Dec	
WS 001 Influent Waste Stream	Solids, Total Suspended (TSS)							Monitor only. calendar month average	milligrams per liter	3 times per week	24-Hour Flow Composite	Jan-Dec	